

Vibromak[®]

Surface finishing
technologies.



VIBRATORY WHEEL POLISHING MACHINES VKJ SERIES

VKJ machine is a universal process machine, finishing parts at 1500 rpm or 3000rpm. Polishing of the die cast molds, medical implants and instruments, smoothing of the aerospace engine parts, forging dies, grinding and smoothing of the 3D/AM metal parts. It produces repeatable and constant finish.



FOR MORE INFO
PLEASE CONTACT
branko@massfin.ca
1(519)739-0733

Test Lab Address: 4325 County Rd. 42, Windsor, Ontario, N9A 6J3

WWW.MASSFIN.CA

www.massfin.ca

Vibratory Wheel Polishing Machines



- Additional Accesories:**
- Pneumatic Sound Cover
 - Pneumatic Unload Gate
 - Frequency Control
 - Dossage Pump
 - Magnetic valve
 - Control Panel Base
 - Rinsing pipe(different types)

VKJ series machines can be used for surface finishing of new or used automotive and motor bike wheels of up to 24" diameter.

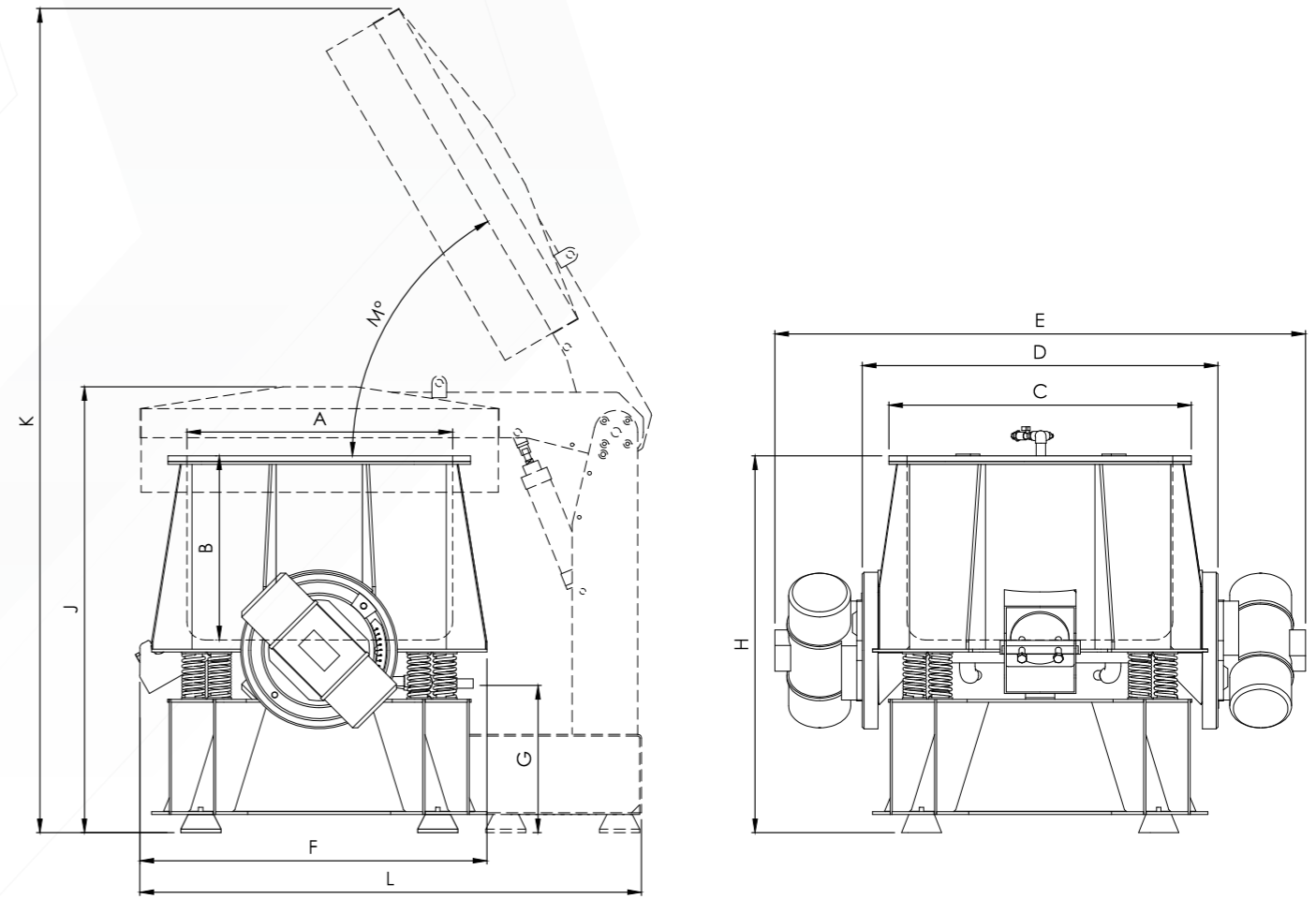

Teknik Ölçüler Technical Dimensions

TİP / TYPE	Gross Volume	Usable Volume	PU Thickness	Motor Power	Operating Speed	Weight					
	Lt	Lt	mm	kW	rpm	Kg					
VKJ140	193	141	15-25	2 x 1,1	1500	680					
A	B	C	D	E	F	G	H	J	K	L	M
mm	mm	mm	mm	mm	mm	mm	mm	mm	mm	mm	°
720	500	830	980	1460	950	410	1030	1250	2280	1380	60



Adjustable Motor Position

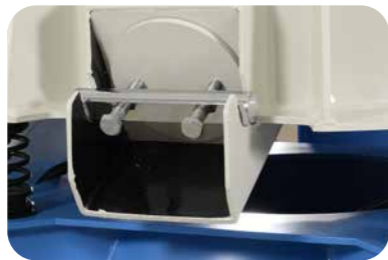

Media Unload Gate



Electrical Control Panel

